



Integrated Amplifier



MA6900 Owner's Manual

The lightning flash with arrowhead, within an equilateral triangle, is intended to alert the user to the presence of uninsulated "dangerous voltage" within the product's enclosure that may be of sufficient magnitude to constitute a risk of electric shock to persons.



AVIS RISQUE DE CHOC ELECTRIQUE - NE PAS OUVRIR.

The exclamation point within an equilateral triangle is intended to alert the user to the presence of important operating and maintenance (servicing) instructions in the literature accompanying the appliance.

WARNING - TO REDUCE RISK OF FIRE OR ELECTRICAL SHOCK, DO NOT EXPOSE THIS EQUIPMENT TO RAIN OR MOISTURE.

NO USER-SERVICEABLE PARTS INSIDE. REFER SERVICING TO QUALIFIED PERSONNEL.

To prevent the risk of electric shock, do not remove cover or back. No user serviceable parts inside.

IMPORTANT SAFETY INSTRUCTIONS!

PLEASE READ THEM BEFORE OPERATING THIS EQUIPMENT.

1. Read these instructions.
2. Keep these instructions.
3. Heed all warnings.
4. Follow all instructions.
5. Do not use this apparatus near water.
6. Clean only with a dry cloth.
7. Do not block any ventilation openings. Install in accordance with the manufacturer's instructions.
8. Do not install near any heat sources such as radiators, heat registers, stoves, or other apparatus (including amplifiers) that produce heat.
9. Do not defeat the safety purpose of the polarized or grounding-type plug. A polarized plug has two blades with one wider than the other. A grounding type plug has two blades and a third grounding prong. The wide blade or the third prong are provided for your safety. If the provided plug does not fit into your outlet, consult an electrician for replacement of the obsolete outlet.
10. Protect the power cord from being walked on or pinched particularly at plugs, convenience receptacles, and the point where they exit from the apparatus.
11. Only use attachments/accessories specified by the manufacturer.
12. Use only with the cart, stand, tripod, bracket, or table specified by the manufacturer, or sold with the apparatus. When a cart is used, use caution when moving the cart/apparatus combination to avoid injury from tip-over.
13. Unplug this apparatus during lightning storms or when unused for long periods of time.
14. Refer all servicing to qualified service personnel. Servicing is required when the apparatus has been damaged in any way, such as power-supply cord or plug is damaged, liquid has been spilled or objects have fallen into the apparatus, the apparatus has been exposed to rain or moisture, does not operate normally, or has been dropped.
15. Do not expose this equipment to dripping or splashing and ensure that no objects filled with liquids, such as vases, are placed on the equipment.
16. To completely disconnect this equipment from the a.c. mains, disconnect the power supply cord plug from the a.c. receptacle.
17. The mains plug of the power supply cord shall remain readily operable.



Thank You

Your decision to own this McIntosh MA6900 Integrated Amplifier ranks you at the very top among discriminating music listeners. You now have “The Best.” The McIntosh dedication to “Quality,” is assurance that you will receive many years of musical enjoyment from this unit.

Please take a short time to read the information in this manual. We want you to be as familiar as possible with all the features and functions of your new McIntosh.

Please Take A Moment

The serial number, purchase date and McIntosh dealer name are important to you for possible insurance claim or future service. The spaces below have been provided for you to record that information:

Serial Number: _____

Purchase Date: _____

Dealer Name: _____

Technical Assistance

If at any time you have questions about your McIntosh product, contact your McIntosh dealer who is familiar with your McIntosh equipment and any other brands that may be part of your system. If you or your dealer wish additional help concerning a suspected problem, you can receive technical assistance for all McIntosh products at:

McIntosh Laboratory, Inc.
2 Chambers Street
Binghamton, New York 13903
Phone: 607-723-1545
Fax: 607-723-3636

Customer Service

If it is determined that your McIntosh product is in need of repair, you can return it to your dealer. You can also return it to the McIntosh Laboratory Service Department. For assistance on factory repair return procedure, contact the McIntosh Service Department at:

McIntosh Laboratory, Inc.
2 Chambers Street
Binghamton, New York 13903
Phone: 607-723-3515
Fax: 607-723-1917

Table of Contents

Safety Instructions	2
Thank You and Please Take a Moment.....	3
Technical Assistance and Customer Service	3
Table of Contents	3
Important Information	4
Connector Information	4
Introduction	4
Performance Features	4
Dimensions	5
Installation	6
Rear Panel Connections and Switch	7
How to Connect for Loudspeakers	8
How to Connect for Audio and Data Control	9
How to Connect for Video	10
How to Connect for a Second Room	11
Front Panel Controls, Display, Indicator Push-Button and Switch	12
How to Operate	13
Remote Control Push-Buttons	16
How to Operate by Remote Control	17
Technical Description	18
Specifications	22
Packing Instruction	23

Important Information

1. The following parts are available from the McIntosh Parts Department:
 - Power Control Cable Part No. 170-202**
Six foot, 2 conductor shielded, with two 1/8 inch stereo mini phone plugs.
 - Jumper Plugs Part No. 117-781**
RCA Phono Jumpers, 14mm center spacing.
2. For additional connection information, refer to the owner's manual(s) for any component(s) connected to the MA6900.
3. The MA6900 mutes the speaker outputs for approximately two seconds when first turned on.
4. It is very important that loudspeaker cables of adequate size be used, so that there will be no power loss. The size is specified in Gauge Numbers or AWG (American Wire Gauge). The smaller the Gauge number, the larger the wire size:
 - If your loudspeaker cables are 50 feet (38.1m) or less, use at least 14 Gauge.
 - If your loudspeaker cables are 100 feet (76.2m) or less, use at least 12 Gauge.
5. In the event that the MA6900 over heats, due to improper ventilation and/or high ambient temperature, the protection circuits will activate. The Front Panel Power Guard LEDs will continuously indicate ON and the audio will be muted. When the MA6900 has returned to a safe operating temperature, normal operation will resume.

Connector Information

XLR Connectors

Below is the Pin configuration for the XLR Balanced Input Connectors on the MA6900. Refer to the diagram for connection:

- PIN 1: Shield/Ground
- PIN 2: + Input
- PIN 3: - Input

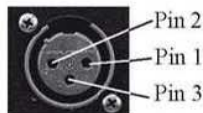

Power Control and Trigger Connectors

The MA6900's Power Control Outputs provide a 5 volt signal. Use a 1/8 inch stereo mini phone plug to connect to the Power Control Input on other McIntosh Components.

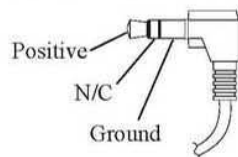

Data Port Connector

The MA6900's Data Port Output provides Remote Control Signals. Use a 1/8 inch stereo mini phone plug to connect to the Data Port Inputs on McIntosh Source Units.

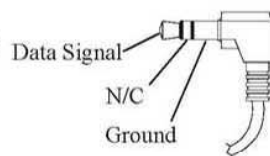

Introduction

Now you can take advantage of traditional McIntosh standards of excellence in the MA6900 Integrated Amplifier. Two 200 watt high current output channels will drive any high quality loudspeaker system to its ultimate performance and the flexible Preamplifier Selection provides for hookup and control of various input sources. The MA6900 reproduction is sonically transparent and absolutely accurate. The McIntosh Sound is "The Sound of the Music Itself."

Performance Features

● Power Output

The MA6900 consists of two separate power amplifier channels, each capable of 200 watts into 2, 4 or 8 ohm speakers with less than 0.005% distortion.

● Electronic Input Switching

Digital Logic integrated circuits drive Electromagnetic Switches on all six inputs and operating functions for reliable, noiseless, distortion free switching.

● Power Guard

Both channels include the patented McIntosh Power Guard circuit that prevents the amplifier from being overdriven into clipping, with its harsh distorted sound that can also damage your valuable loudspeakers.

● Sentry Monitor and Thermal Protection

McIntosh Sentry Monitor power output stage protection circuits ensure the MA6900 will have a long and trouble free operating life. Built-in Thermal Protection Circuits guard against overheating.

● Patented Autoformers

McIntosh designed and manufactured Output Autoformers provide an ideal match between the amplifier output stages and speaker loads of 2, 4 and 8 ohms. The Autoformers also provide perfect DC protection for your valuable loudspeakers.

● Illuminated Power Meters

The Illuminated Power Output Meters on the MA6900 are peak responding, and indicate the power output of the amplifier.

MA6900 Dimensions

The following dimensions can assist in determining the best location for your MA6900. There is additional information on the next page pertaining to installing the MA6900 into cabinets.

Front View of the MA6900



Rear View of the MA6900



Side View of the MA6900

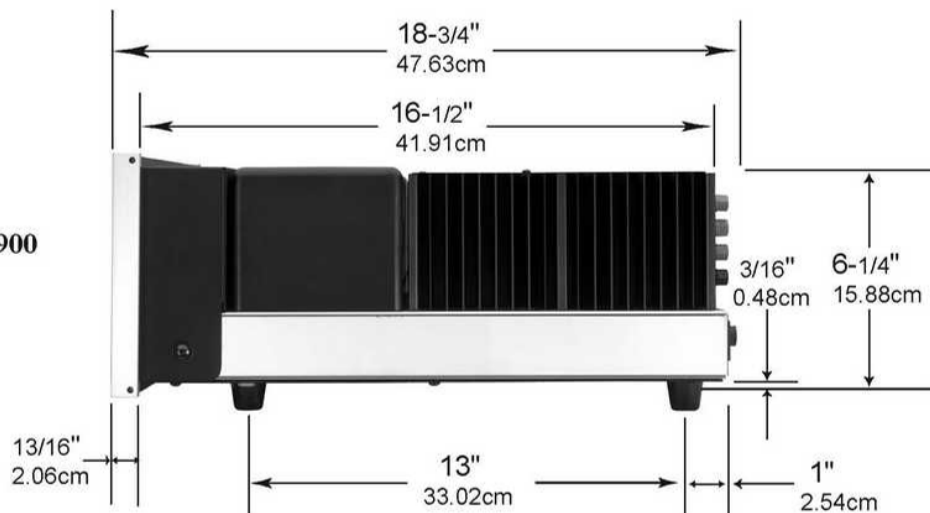

Installation

The MA6900 can be placed upright on a table or shelf, standing on its four feet. It also can be custom installed in a piece of furniture or cabinet of your choice. The four feet may be removed from the bottom of the MA6900 when it is custom installed as outlined below. The four feet together with the mounting screws should be retained for possible future use if the MA6900 is removed from the custom installation and used free standing. The required panel cutout, ventilation cutout and unit dimensions are shown.

Always provide adequate ventilation for your MA6900. Cool operation ensures the longest possible operating life for any electronic instrument. Do not install the MA6900 directly above a heat generating component such as a high powered amplifier. If all the components are installed in a single cabinet, a quiet running ventilation fan can be a definite asset in maintaining all the system components at the coolest possible operating temperature.

A custom cabinet installation should provide the following minimum spacing dimensions for cool operation. Allow at least 6 inches (15.24cm) above the top, 2 inches (5.08cm) below the bottom and 1 inch (2.54cm) in front of the mounting panel for knob clearance. Be sure to cut out a ventilation hole in the mounting shelf according to the dimensions in the drawing.

(2.54cm) on each side of the amplifier, so that airflow is not obstructed. Allow 20 inches (50.8cm) depth behind the front panel. Allow 1 inch (2.54cm) in front of the mounting panel for knob clearance. Be sure to cut out a ventilation hole in the mounting shelf according to the dimensions in the drawing.

MA6900 Front Panel Custom Cabinet Cutout

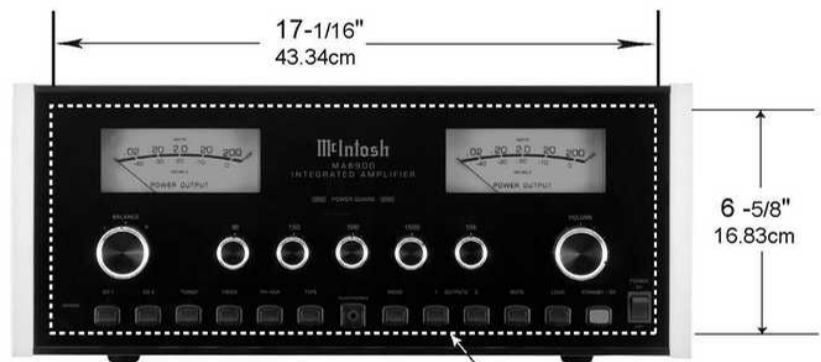

MA6900 Side View in Custom Cabinet

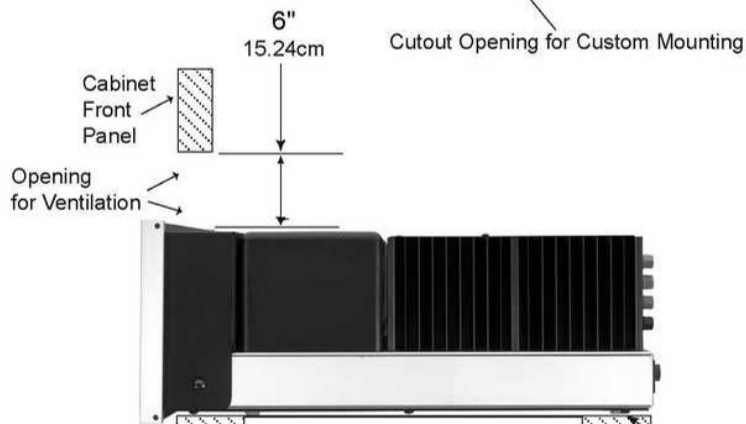

MA6900 Bottom View in Custom Cabinet

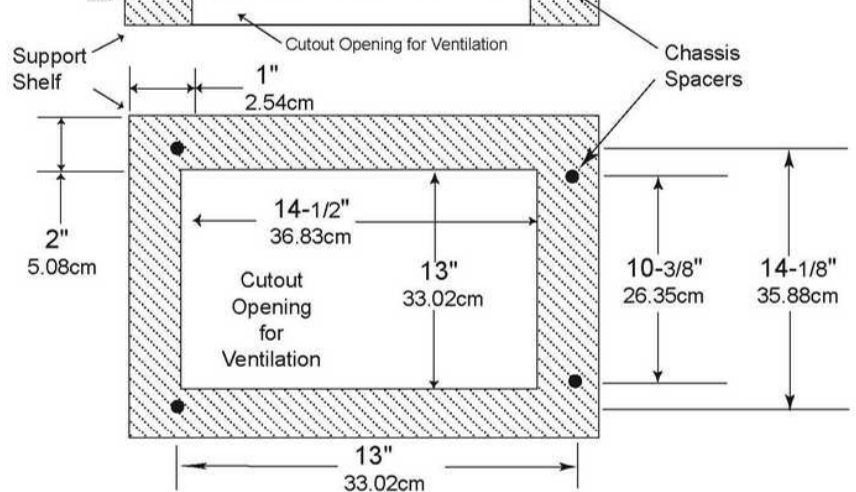

MA6900 Rear Panel Connections and Switch

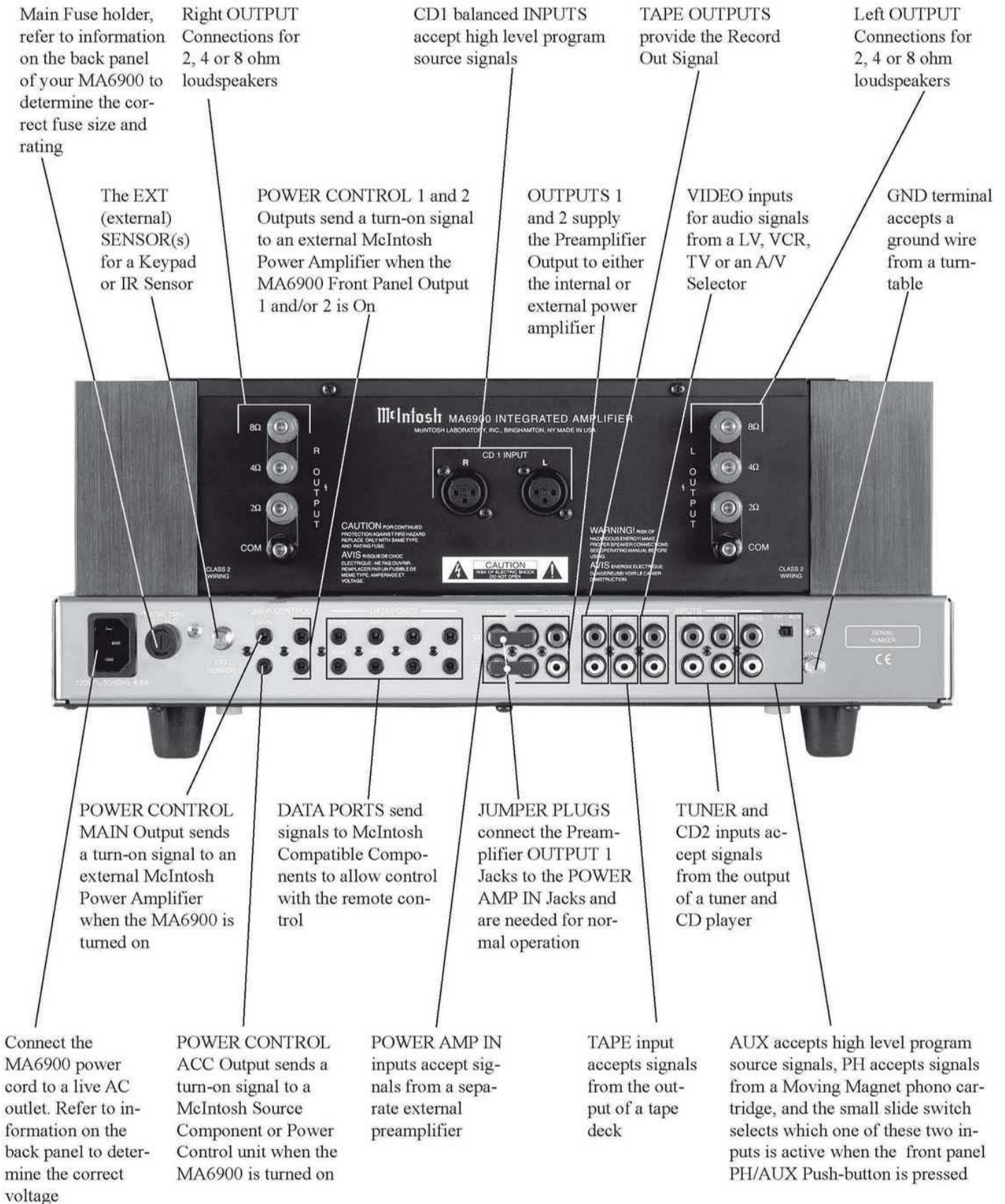

How to Connect Loudspeakers

Caution: The supplied AC Power Cord should not be connected to the Rear Panel of the MA6900 Amplifier until after the Loudspeaker Connections have been made. Failure to observe this could result in Electric Shock.

1. Prepare the Loudspeaker Hookup Cables that attach to the Amplifier by choosing one of the methods below:

Bare wire cable ends:

Carefully remove sufficient insulation from the cable ends, refer to figures 1, 2 & 3. If the cable is stranded, carefully twist the strands together as tightly as possible.

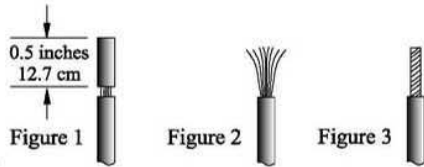

Note: If desired, the twisted ends can be tinned with solder to keep the strands together, or attach spade lug and/or banana connector.

Spade lug or prepared wire connection:

Insert the spade lug connector or prepared section of the cable end into the terminal side access hole, and tighten the terminal cap until the cable is firmly clamped into the terminal so the wires cannot slip out. Refer to figures 4, 5 & 6.

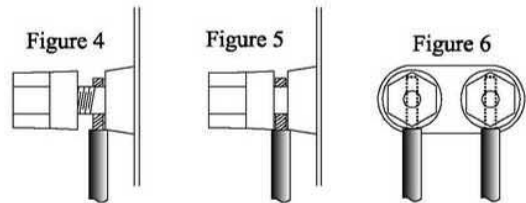

Banana plug connection:

Insert the banana plug into the hole at the top of the terminal.

Note: Banana Plugs are for use in the United States and Canada only.

2. Connect the loudspeaker hookup cables to the output terminals that match the impedance of your loudspeakers, being careful to observe the correct polarities. Output impedance connections of 2 ohms, 4 ohms and 8 ohms are provided. If the impedance of your loudspeakers is in-between the available connections, use the nearest lower impedance connection.

WARNING: Loudspeaker terminals are hazardous live and present a risk of electric shock. For additional instruction on making Loudspeaker Connections contact your McIntosh Dealer or McIntosh Technical Support.

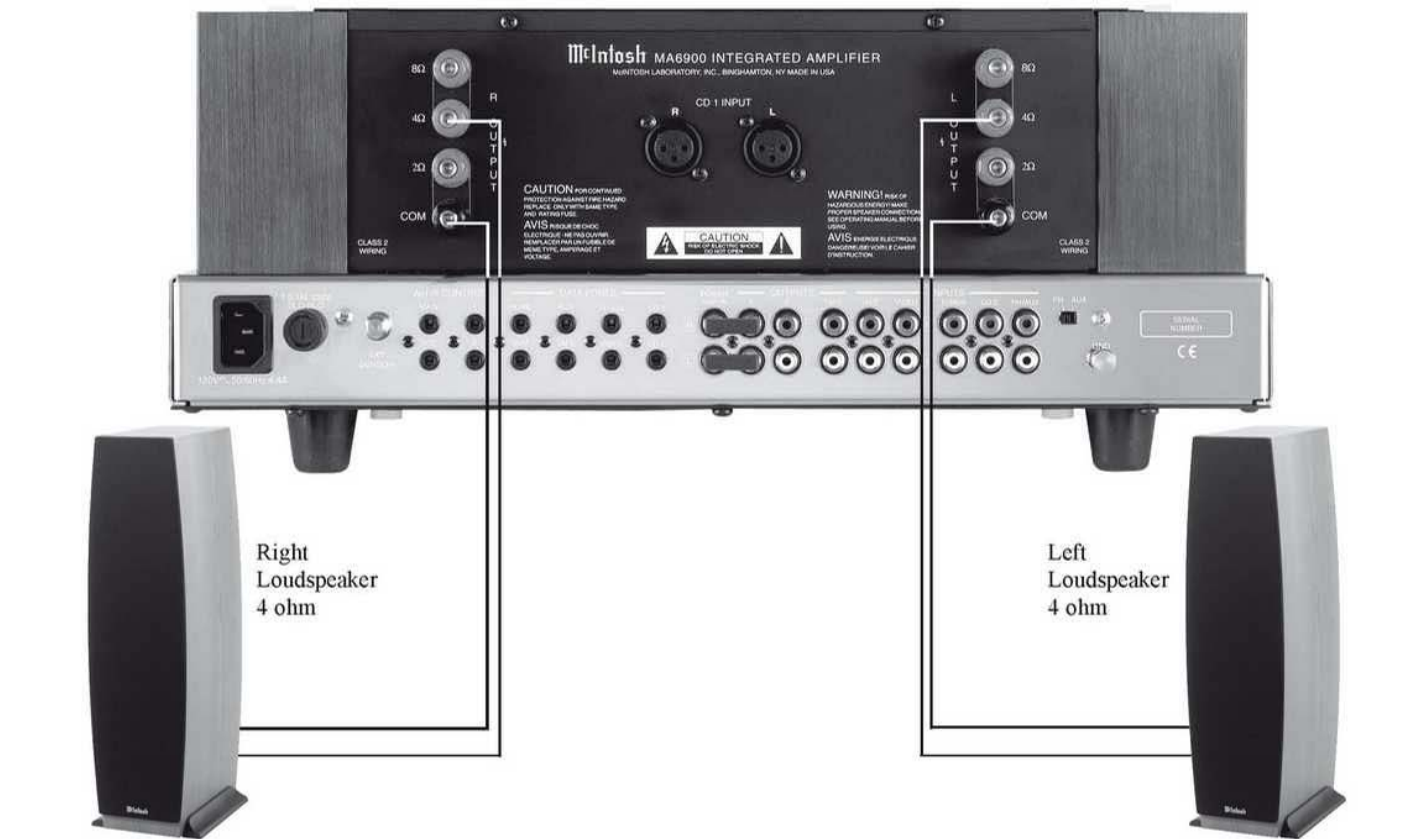

How to Connect Audio Components

1. Connect an Audio Cable from the McIntosh CD Player Audio Outputs to the MA6900 CD2 INPUTS.
2. Connect an Audio Cable from a McIntosh Tuner 1 Outputs to the MA6900 TUNER INPUTS.
3. Connect an Audio Cable from a Turntable to the PH/AUX INPUTS and the Turntable Ground Connection to the GND grounding post.
4. Connect an Audio Cable from the MA6900 TAPE OUTPUTS to the Record Inputs of a Tape Recorder and from the MA6900 TAPE INPUTS to a Tape Recorder Outputs.
5. Connect a Control Cable from the MA6900 POWER CONTROL ACC Jack to the Power Control In on the McIntosh Tuner.
6. Connect a Control Cable from the McIntosh Tuner Power Control Out Jack to the Power Control In jack on the McIntosh CD Player.
7. Connect a Control Cable from the MA6900 TUNER DATA PORT Jack to the McIntosh Tuner Data In (Tuner 1).
8. Connect a Control Cable from the MA6900 CD2 DATA PORT Jack to the McIntosh CD Player Data In Jack.
9. Connect the MA6900 Power Cord to a live AC outlet.

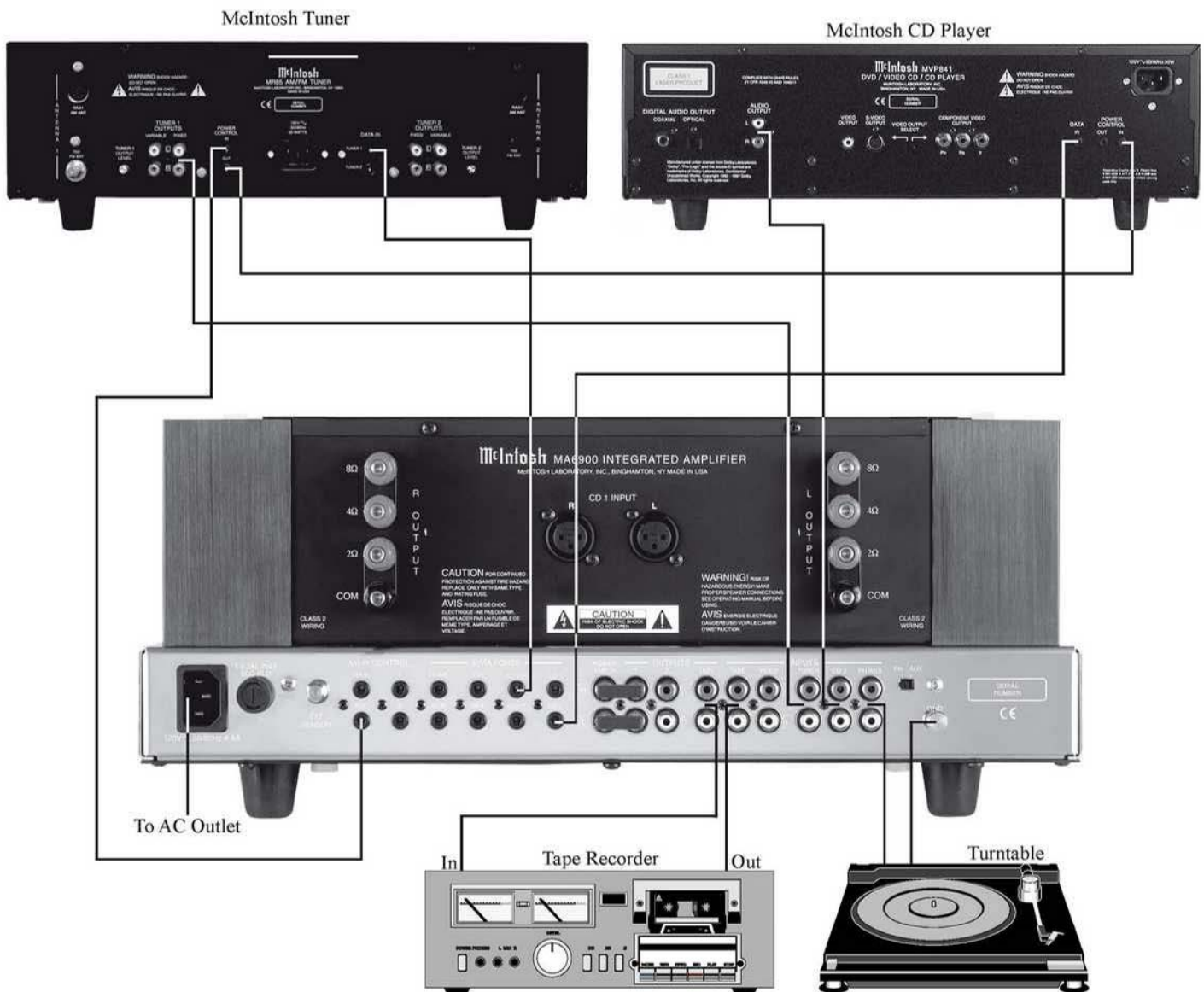

How to Connect for Video Switching

1. Connect a Data cable from the MA6900 VIDEO DATA PORT to the Audio/Video Selector Data In jack.
2. Connect the Audio/Video Selector Control Center Audio Outputs to the MA6900 VIDEO INPUTS.
3. Connect the Audio/Video Selector Video Monitor Output to a Monitor/TV.

Note: Either or both Audio/Video Selector Monitor Output(s) may be connected to the Monitor/TV.

4. Connect a McIntosh DVD/CD Player Audio Outputs to the Audio/Video Selector V-Aux Audio Inputs, the

5. Connect a Control Cable from the MA6900 POWER CONTROL ACC Jack to the Power Control In on the McIntosh DVD/CD Player.
6. Connect other video source components to the appropriate audio and video and data jacks on the Audio/Video Selector.

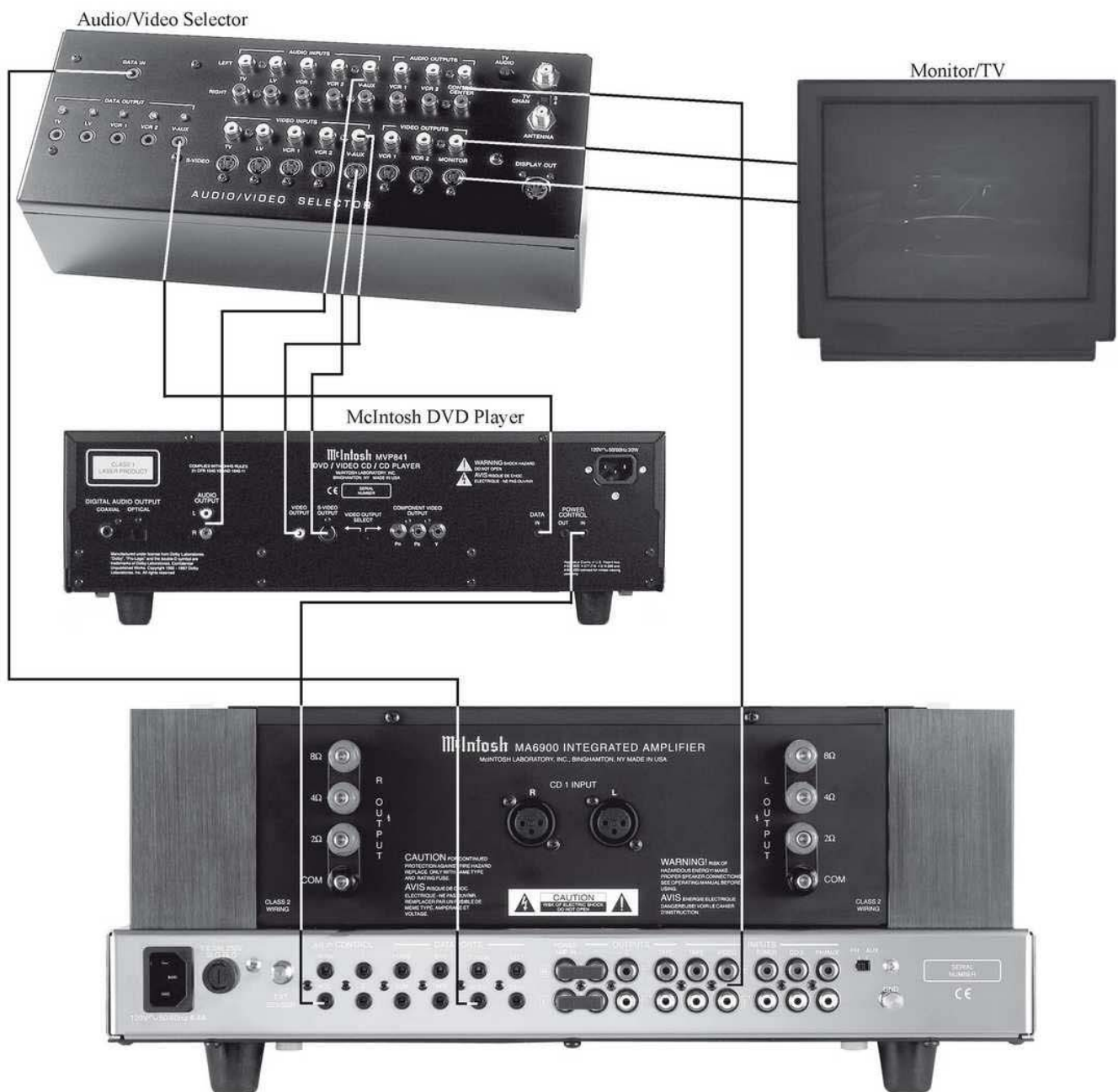

How to Connect for a Second Room

1. Connect Audio Cables from the MA6900 OUTPUTS 2 to the Second Power Amplifier Inputs.
2. Connect Hookup Cables from the Second Power Amplifier to the loudspeakers. Refer to page 8 in this Owner's Manual for connection details.
3. Connect a Control Cable from the MA6900 POWER CONTROL 2 Jack to the Power Control In of a McIntosh Power Amplifier.
4. Connect an RG6 or RG59U coaxial cable from the EXTERNAL SENSOR Jack to a Keypad.

Note: A Wall Mounted IR Sensor may also be used in place of the keypad.

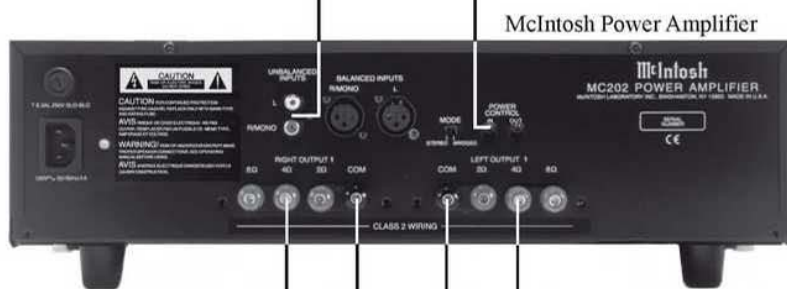

Right Loudspeaker
4 ohm



Left Loudspeaker
4 ohm

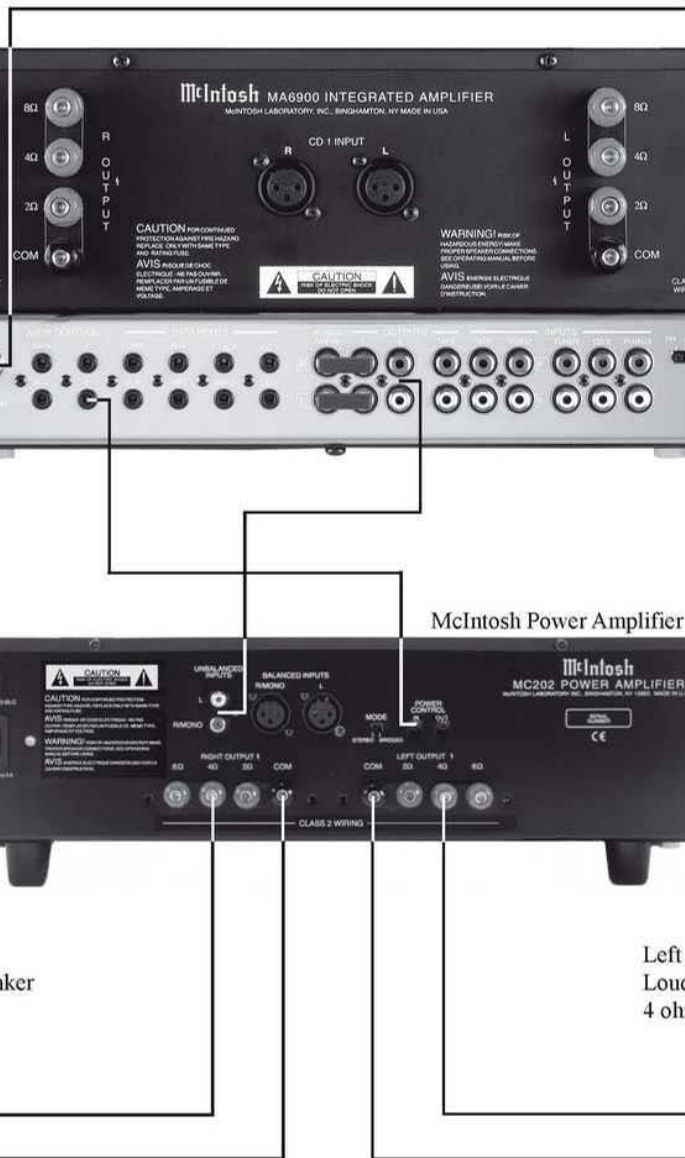

The BALANCE control allows adjustment of the relative volume balance between channels

Equalizer provides 12dB of boost or cut at the center frequencies indicated above each control

METER indicates the Right Channel Power Output of the amplifier

POWER switch turns all AC power completely ON or OFF

METER indicates the Left Channel Power Output of the amplifier

POWER GUARD LEDs light when the amplifier's channel POWER GUARD circuit activates

VOLUME control allows adjustment of the listening level for both channels



IR Sensor receives commands from a remote control

Select any one of the six Audio signal sources

HEADPHONES jack allows connection of Stereo Headphones for private listening

MONO push-button combines the left and right channel signals for Mono operation

OUTPUTS 1 and 2 push-buttons turn the Speakers and Preamplifier Outputs On or Off

MUTE push-button mutes the listening audio

LOUDNESS provides frequency response contoured to compensate for the behavior of the human ear at softer listening levels

STANDBY/ON push-button turns the MA6900 ON, or OFF (Standby)

How to Operate

Power On

Press the POWER switch to ON. The Red LED above the STANDBY/ON push-button, lights to indicate the MA6900 is in Standby mode. To turn On the MA6900, press the STANDBY/ON push-button. The MUTE LED will light for approximately two seconds after turn on. Refer to figures 1 and 2.



Figure 1

Notes: For normal operation, turn the MA6900 On and Off with the Standby/On push-button. If the amplifier is not going to be used for an extended time, turn off all AC Power with the Power Switch. You may also turn On the MA6900 by simply pressing the desired Source Selection Push-button on the Front Panel or Remote Control. For an explanation of the Remote Control Push-button functions, refer to pages 16 and 17.

Source Selection

Select the desired source with the appropriate push-button switch on the Front Panel or Remote Control. Refer to figures 2 and 3 and page 16 for additional information.

Volume Control

Adjust the VOLUME control for the desired listening level.



Figure 2



Figure 3

PH/AUX Inputs

When using a phono player with a moving magnet cartridge connected to the PH/AUX inputs, set the PH AUX switch to the PH position. When using an auxiliary program source component connected to the PH/AUX inputs, set the PH AUX switch to the AUX position. Refer to figure 4.



Figure 4

Balance Control

Adjust the BALANCE control as needed to achieve approximately equal listening volume levels in each loudspeaker. Turn the BALANCE to the left to emphasize the Left Channel by reducing the level of the Right Channel. Turn the BALANCE to the right to emphasize the Right Channel by reducing the level of the Left Channel.

Equalizer Controls

Each of the five Equalizer Frequency Controls will raise or lower by approximately 12dB, the amplitude of the band of frequencies centered at the frequency marked above the controls. Both Left and Right Channels are affected. Refer to figure 5. At the center detent or flat position of the controls, all equalizer circuit components are removed from the signal path.



Figure 5

Loud Switch

Press the LOUD push-button to add loudness bass compensation to the volume control for improved low level listening.

Mono

Press the MONO push-button to combine left and right stereo signals to mono at the SPEAKERS 1 and 2 and HEADPHONES output.

Mute

Press the MUTE push-button to mute audio in all outputs except the HEADPHONES and TAPE OUTPUT. The MUTE LED above the push-button will flash on and off to indicate that Mute is active. To unmute audio, press MUTE, press the Remote Control Volume push-button(s) or press an Input push-button.

Outputs 1 and 2

Press OUTPUTS Push-button 1 to switch the Speakers On or Off. The push-buttons also switch the Preamplifier OUTPUTS 1 and 2 On or Off



Figure 6

for connection to external Power Amplifier(s). Press either push-button individually, or both together. Refer to figure 6.

Headphones Jack

Connect a pair of dynamic headphones to the Headphones Jack for private listening. Press Mute to mute all other outputs including the amplifier connected to the loudspeakers. Refer to figure 6.

Reset of Microprocessors

In the event that the controls of the MA6900 stop functioning, push the POWER switch OFF and wait about two minutes. Then push the POWER switch ON followed by pushing the STANDBY/ON push-button. This will reset the MA6900 microprocessors and the Integrated Amplifier should be functioning normally.

Note: The above condition is usually caused by either interruptions in AC power and/or major changes that may occur in AC power line voltage.

Using a Separate Power Amplifier

There are two different ways to use a separate power amplifier with a MA6900. The first way is to use the separate amplifier instead of the MA6900 built-in Power Amplifier. Connect the loudspeakers to the separate power amplifier and remove the McIntosh Jumpers that are located between the OUTPUTS 1 Jacks and the POWER AMP Input Jacks. Refer to figures 7 and 8.



Figure 7

Note: The McIntosh Jumpers must be connected, between the above mentioned jacks, when the MA6900 Internal Power Amplifier is to be used.

The second way is to use both a separate power amplifier and the MA6900 built-in Power Amplifier. Connect one pair of loudspeakers to the separate power amplifier and the second pair to the MA6900.



Figure 8

Note: The MA6900 VOLUME Control will affect the sound level of all the loudspeakers.

How To Make A Tape Recording

1. Select the source signal you wish to record with the appropriate Front Panel input push-button. If you wish to record from an Audio/Video source connected to the optional McIntosh Audio/Video Selector Audio/Video Selector, using the Remote Control, select the desired source connected to the McIntosh Audio/Video Selec-



Figure 9

tor. Refer to figure 9.

2. Adjust the record level using the tape recorder volume control and proceed with the recording process.
3. To listen to the tape playback of the program source just recorded, press the TAPE input push-button.

Note: The MA6900 TAPE OUTPUTS are not affected by the VOLUME or BALANCE controls.

Power Output Meters

The MA6900 Power Output Meters indicate the power delivered to the loudspeakers. The meters respond to all the musical information being produced by the amplifier. They indicate to an accuracy of at least 95% of the power output with only a single cycle of a 2000Hz tone burst.

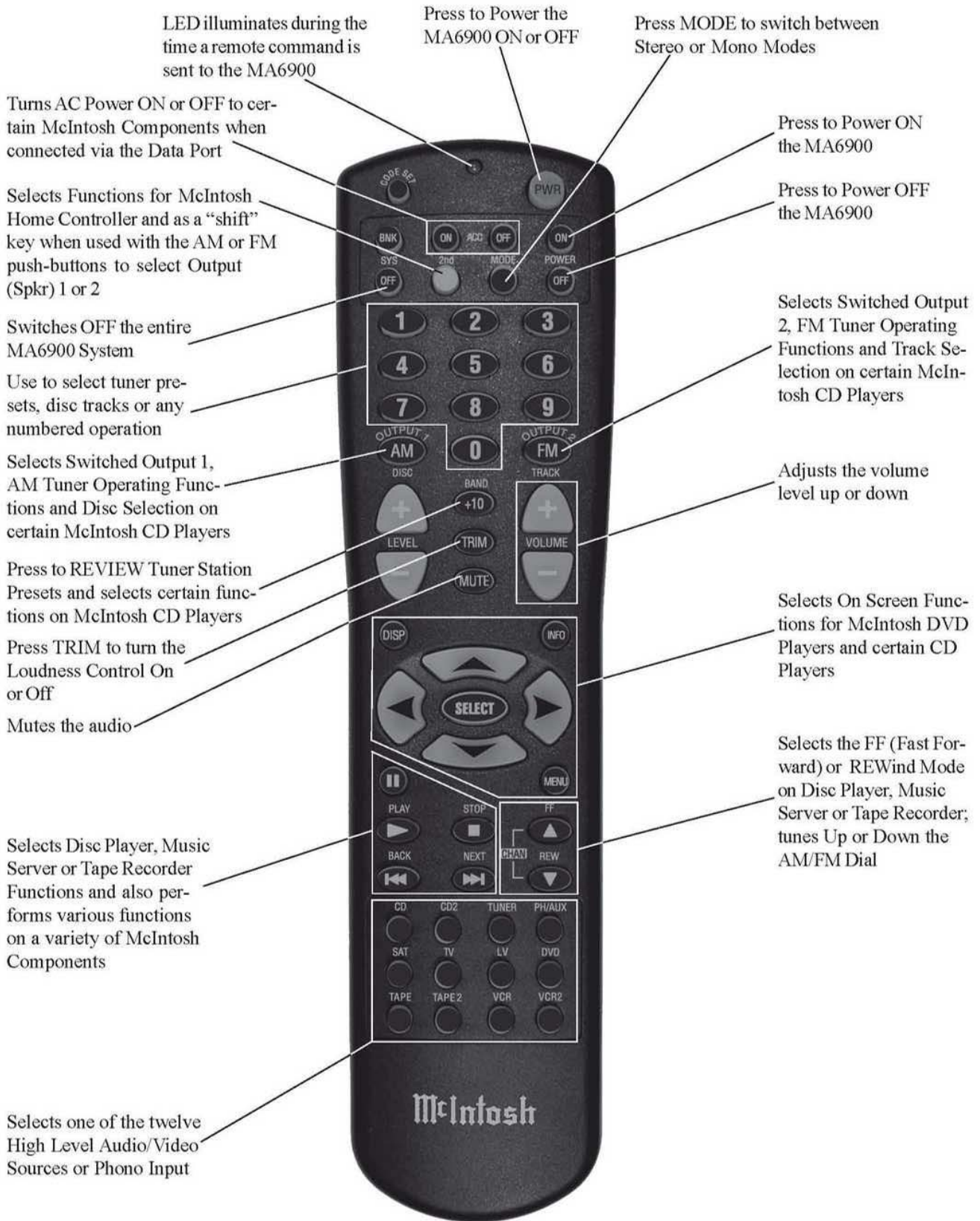

Note: Push-buttons whose function is not identified above are for use with other McIntosh Products.

How to Operate by Remote Control

The supplied remote control is capable of directly controlling the functions of contemporary McIntosh Source Components connected to the MA6900. Earlier McIntosh source components and other brand source components can be controlled by the MA6900 Remote Control with the addition of a McIntosh Remote Control Translator (RCT).

Note: Your McIntosh Dealer can assist you with the installation and operation of the Remote Control Translator (RCT).

Mute

Press the MUTE push-button to mute audio at the Preamplifier OUTPUTS 1, 2 and Speaker L, R OUTPUTS. The TAPE OUTPUTS and HEADPHONES output are not affected by the MUTE function. The MUTE LED above the push-button will flash on and off to indicate that Mute is active. Press MUTE a second time to unmute audio.

Mono

Press the MODE push-button to combine left and right stereo signals to mono at the Preamplifier OUTPUTS 1, 2 and Speaker L, R OUTPUTS.

Trim

Press the TRIM push-button to active the Loudness Compensation circuit.

Input Source Selection

Press any of the twelve input push-buttons to select a program source. When one of the Audio/Video Inputs (SAT, LV, TV, VCR, VCR2 and DVD) are selected by remote control, the MA6900 will automatically switch to the VIDEO Input. If the Front Panel VIDEO Push-button is pressed, the source device connected to the VIDEO INPUT Jacks will be heard. When the optional McIntosh MVS Audio/Video Selector is added, multiple Audio/Video Inputs Sources, such as LV, TV, VCR, VCR2 and DVD (V-Aux), will become available by just pressing the desired program source push-button on the remote control.

Disc Player, Music Server or Tape Recorder Functions

Use these push-buttons to operate a CD player, CD changer or tape recorder.

Numbered Push-buttons

Press push-buttons 0 through 9 to access tuner station presets or CD tracks/discs.

Disc and Track

Use the DISC and TRACK push-buttons when a Disc Player, Music Server or Tape Recorder exis being used.

Tuner Push-buttons

Press the AM or FM push-button to select the desired broadcast band. Press and release the CHANNEL Up▲ or Down▼ push-button to move from station to station. Press and hold a CHANNEL Up▲ or Down▼ push-button to move continuously from station to station. Press the +10 Push-button to start the automatic brief audition of each of the presets stored in the tuner memory. Press the +10 Push-button a second time to stop on a station preset and exit the review process.

Volume

Press the Up or Down VOLUME push-button to raise or lower the listening volume level.

Note: The TAPE OUPUTS are not affected by volume changes.

Amplifier Selection

Press the 2nd push-button followed by the OUTPUT 1 or 2 push-buttons to control the rear panel OUTPUTS 1, 2 which can feed signals to a power amplifier or other accessory component.

Acc On

Press ACC ON to turn the power ON to a McIntosh Disc Player.

Acc Off

Press ACC OFF to turn the power OFF to a McIntosh Disc Player.

Pause

Press **II** to perform various functions on a variety of McIntosh Components. It will also pause the playing of a disc or tape player.

McIntosh

Technical Description

McIntosh Laboratory, the company who introduced the world's first amplifier that could be called "High Fidelity", has done it again. The McIntosh engineering staff has created a power amplifier without compromise, using the most advanced McIntosh circuit design concepts.

A continuous average power output rating of 200 watts and with an output current of greater than 50 amperes per channel, making this the most advanced Integrated Amplifier McIntosh has ever manufactured. The distortion limits for the MA6900 are no more than 0.005% at rated power output for all frequencies from 20Hz to 20,000Hz. Typical performance at mid frequencies is less than 0.002%. The true distortion readings on the MA6900 are so low, it takes special measuring techniques to make accurate readings. The MA6900 can deliver the best possible performance from any type of high quality loudspeaker system.

Creating an amplifier with this level of performance did not come easily. Many months of design, testing and measuring were required. Extensive controlled listening tests, the ultimate form of measuring, were made before the final design was accepted.

Preampifier Design Philosophy

All signal switching in the MA6900 is done by Electro-Magnetic devices. Electro-Magnetic Switching is a proven technology that uses the latest in materials and manufacturing methods. Each switch consists of a glass tube that is filled with an inert oxygen-free atmosphere and sealed with tiny leads protruding from either end. These leads extend into the tube and overlap one another with a separation of a few thousandths of an inch. The leads are made from a ferrous material that is influenced by a magnetic field. They are first plated with gold as a base material, then with rhodium and finally ruthenium. Ruthenium is the best contact material known.

The glass assembly is then placed in the center of a multilayer coil of copper wire. The entire assembly is molded together in a tough shock absorbing material.

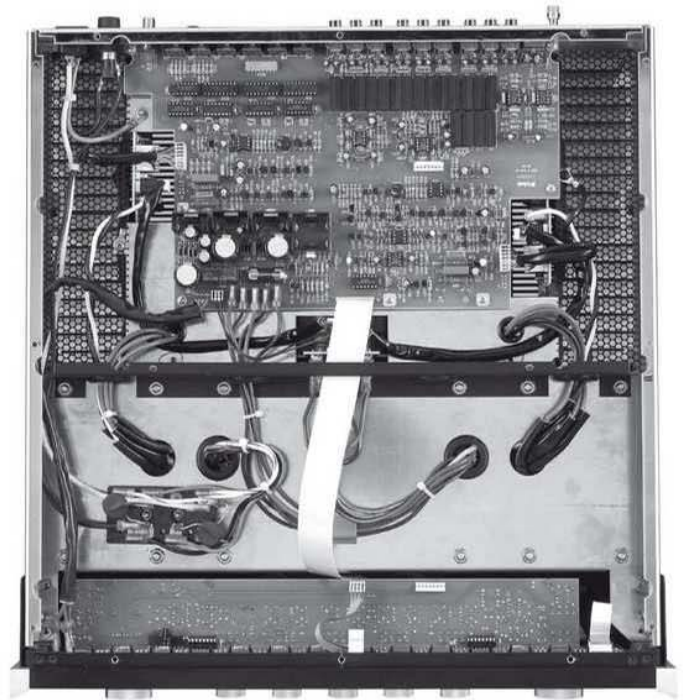

Bottom Inside View of the MA6900

The switch and coil connectors extend from the bottom in the form of printed circuit board terminals. When a DC voltage is applied to the coil, current flows and creates a

Equalizer Control Adjustment Range

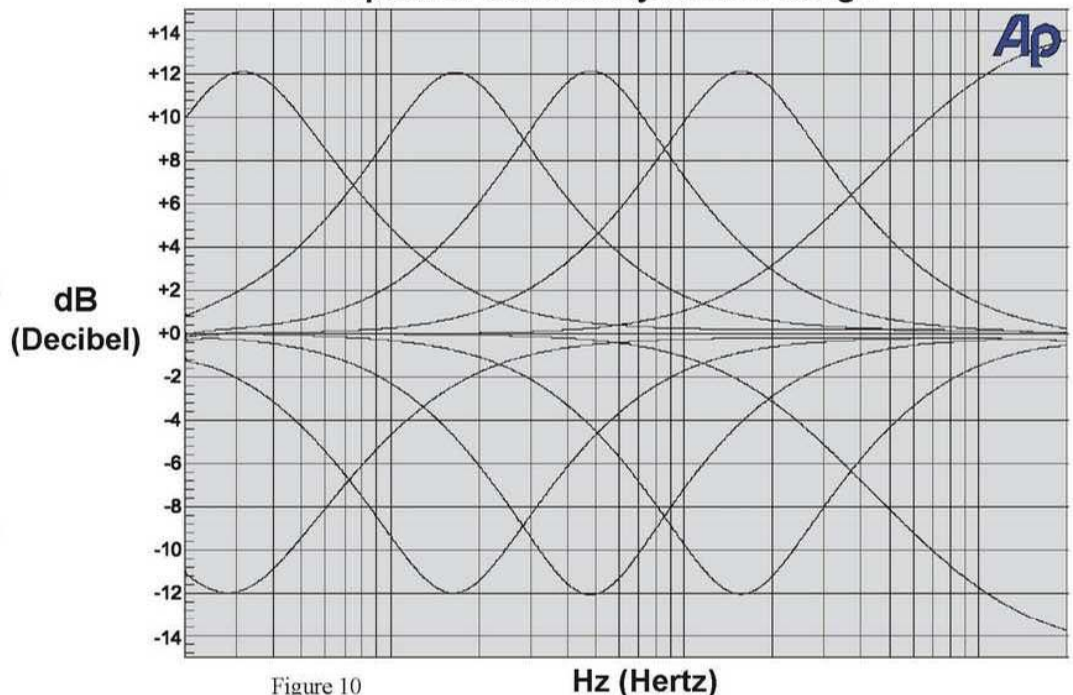

Figure 10

magnetic field. The force of the field causes the leads to bend and contact one another inside the sealed glass tube. The inert gas eliminates corrosion of the contacts and insures a low resistance, distortion free switch.

All inputs, outputs, and data ports are controlled by logic circuits in the MA6900. The logic is changed by front panel push-buttons or by a microprocessor IR decoder. This microprocessor IR decoder is programmed with exclusive McIntosh software. It receives data from the front panel or external sensors and provides the command signals for input switching, data switching, and volume control.

The equalizer section uses several high technology operational amplifiers. The amplifier stage has been optimized for the best transient performance and minimum distortion. Five other operational amplifiers are arranged in a circuit configuration that is the equivalent of a series tuned circuit. A control potentiometer inserts this series tuned circuit into either the feedback or input section of the equalizer amplifier. This provides a 12dB boost or cut at the frequency of the tuned circuit. Refer to figure 10. The overall gain of the stage is 0dB when the potentiometer is at its center detent position. In this position the tone control elements are completely removed from the signal path.

Power Amplifier Design Philosophy

The design philosophy incorporated in the MA6900 involved several different techniques, all based on sound scientific logic. Refer to figure 11. Every stage of voltage or current amplification must be as linear as possible prior to the use of negative feedback. McIntosh engineers know how to properly design negative feedback circuits so they contribute to the extremely low distortion performance expected from a McIntosh amplifier. The typical McIntosh owner would never accept the approximately 100 times higher distortion of many non-feedback designs.

All transistors are selected to have nearly constant current gain over the entire current range they must cover. Output transistors in particular, have matched uniform current gain, high current-bandwidth product and large active region safe operating area. An automatic tracking bias system completely eliminates any trace of crossover distortion. Precision metal film resistors and low dielectric absorption film capacitors are used in all critical circuit locations.

The output signal of the circuit is coupled together in the unique McIntosh MA6900 Output Autoformer. It provides low distortion power transfer at frequencies from below 20Hz to well beyond 20,000Hz with optimum imped-

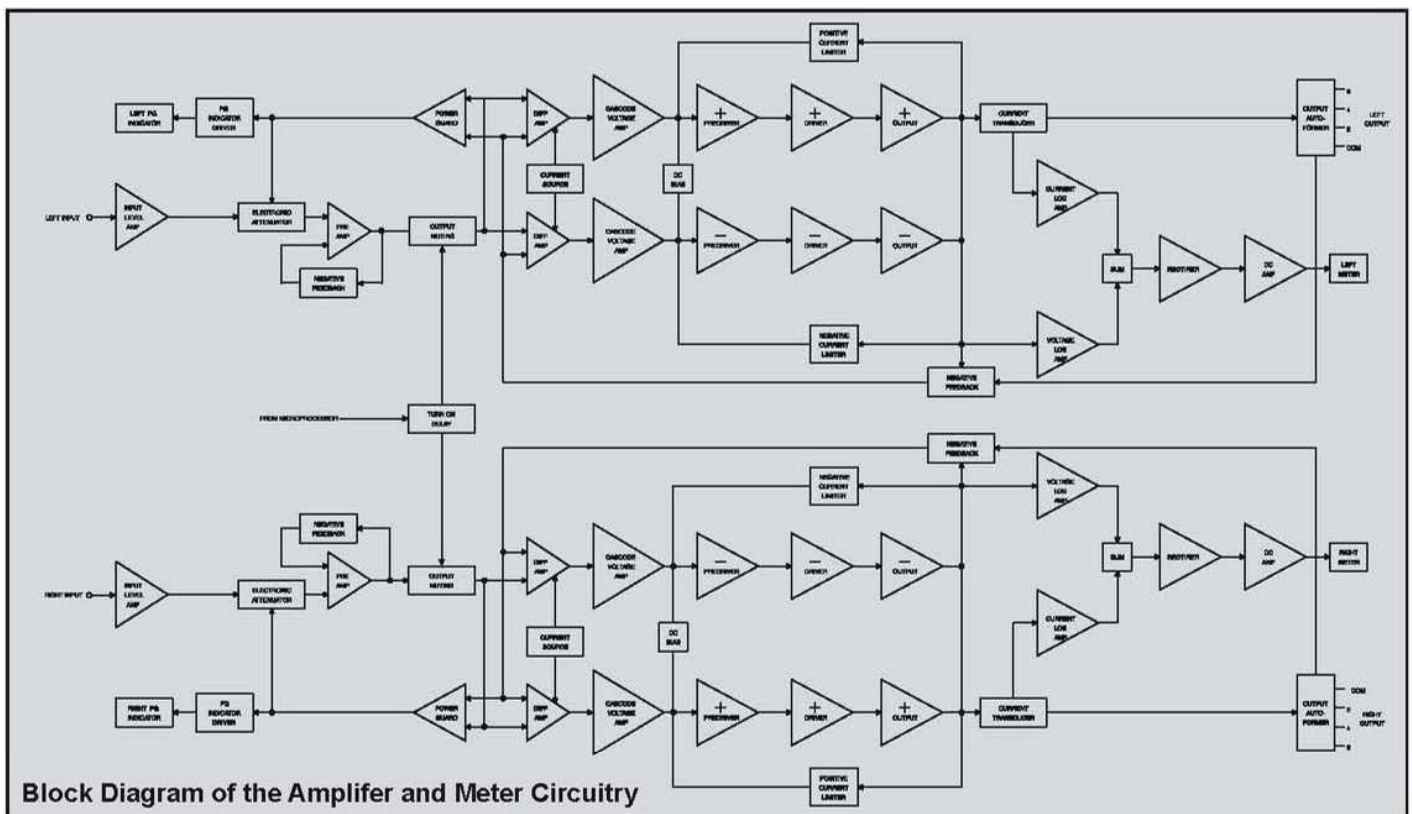

Figure 11



Top Inside View of the MA6900

ance points of two ohms, four ohms and eight ohms. The unequaled expertise of McIntosh in the design and manufacturing of autoformers is legendary in the high fidelity industry.

The high efficiency circuit design of the MA6900 contributes to low operating temperatures. More than 621 square inches of heat sink area keep the MA6900 operating safely with convection cooling. No fans are needed.

Autoformers

All solid state power amplifier output circuits work best into what is called an optimum load. This optimum load may vary considerably from what a loudspeaker requires. In the case of more than one loudspeaker connected in parallel, the load to the power amplifier may drop to two ohms or even less. A power amplifier connected to a load that is lower than optimum, causes more output current to flow, which results in extra heat being generated in the power output stage. This increase in temperature will result in a reduced life expectancy for the amplifier.

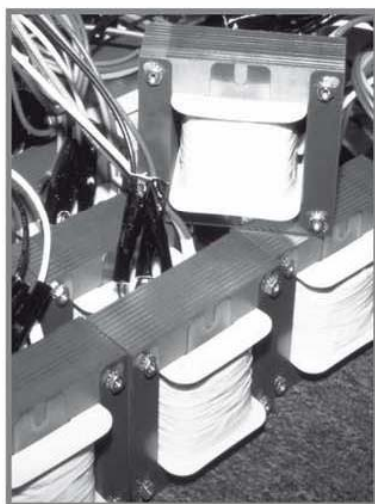

Figure 12

The Autoformer creates an ideal match between the power amplifier output stage and the loudspeaker. Refer to figure 12. There is absolutely no performance limitation with an Autoformer. Its frequency response exceeds that of the output circuit itself, and extends well beyond the audible range. Its distortion level is so low it is virtually impossible to measure. In the rare event of a power amplifier output circuit failure, the McIntosh Autoformer provides absolute protection from possible damage to your valuable loudspeakers.

Protection Circuits

The MA6900 incorporates its version of the McIntosh Sentry Monitor output transistor protection circuit. Refer to figure 13. There is absolutely no compromise in sonic performance with this circuit, and it ensures safe operation of the amplifier under even the most extreme operating conditions. The different types of protection circuits incorporated in the MA6900 insure a long and safe operating life.

The MA6900 also includes the unique patented McIntosh Power Guard circuit.

Power Guard eliminates the possibility of ever overdriving the amplifier into clipping. Refer to figures 14, 15 and 16. An overdriven amplifier can produce both audible and inaudible distortion levels exceeding 40%. The audible distortion is unpleasant to hear, but the inaudible ultrasonic distortion is also undesirable, since it can damage valuable loudspeaker system tweeters. You will never experience the harsh and damaging distortion due to clipping.

The Power Guard circuit is a waveform comparator, monitoring both the input and output waveforms. Under normal operating conditions, there are no differences between the shape of these waveforms. If an amplifier channel is overdriven, there will be a difference between the two signal waveforms. When the difference exceeds 0.3% (equivalent to 0.3% harmonic distortion), the Power Guard activates the



Figure 13

Input Test Signal

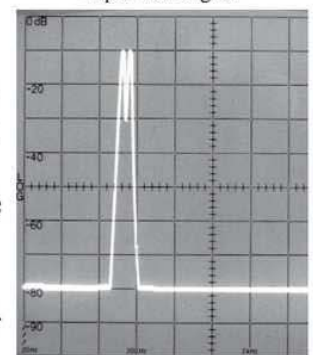

Figure 14

Without Power Guard

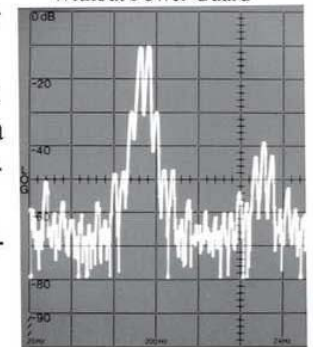

Figure 15

PG light and a dynamic electronic attenuator at the amplifier input reduces the input volume just enough to prevent any further increase in distortion. The Power Guard circuit acts so fast that there are absolutely no audible side effects and the sonic purity of the music reproduction is perfectly preserved. The MA6900 Amplifier with Power Guard is not limited to just the rated power output, but will actually produce distortion free output well above its rated power due to the McIntosh philosophy of conservative design.

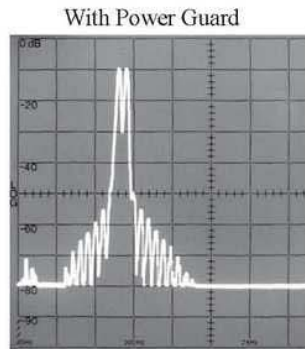

Figure 16

Power Supply Circuits

To compliment the design of the MA6900, there is a high voltage power supply for both channels. Refer to figure 17. The power amplifiers draw high current from the AC power line. Therefore, it is important that they plug directly into the wall outlet. Turn on inrush current is cushioned by thermistors in the power transformer's primary circuit. This soft start eliminates component stress during turn-on.

The MA6900 can provide greater than 50 amperes peak output current to drive uneven speaker loads. Some poor speaker designs have input impedance that dip to 1 or 2 ohms at various frequencies and the MA6900 has the output current reserve to drive them. The MA6900 has main filter capacitors that guarantee an excellent signal to noise ratio and the energy storage necessary for the wide dynamic range that "Digital Audio" demands.

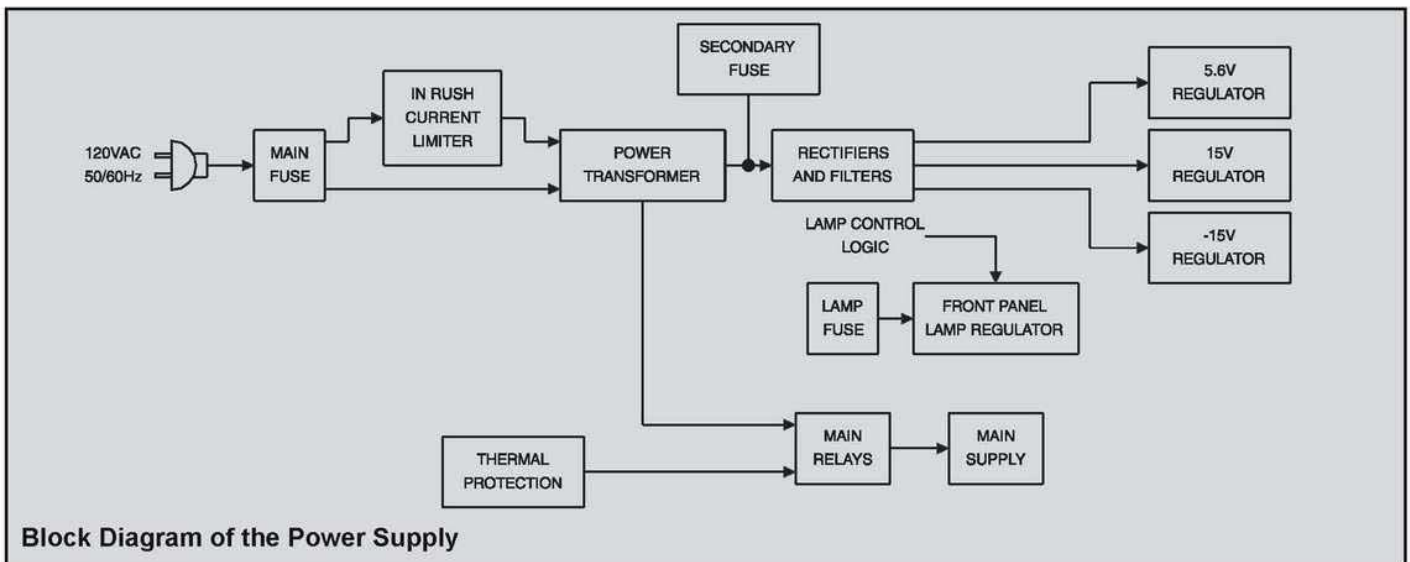

Figure 17

PERFORMANCE SPECIFICATIONS

Power Output

Minimum sine wave continuous average power output per channel, all channels operating is:

- 200 watts into 2 ohm load
- 200 watts into 4 ohm load
- 200 watts into 8 ohm load

Rated Power Band

20Hz to 20,000Hz

Total Harmonic Distortion

Maximum Total Harmonic Distortion at any power level from 250 milliwatts to rated power output is:
0.005% for 2, 4 or 8 ohm loads

Dynamic Headroom

2.4dB

Frequency Response

- +0, -0.5dB from 20Hz to 20,000Hz
- +0, -3dB from 10Hz to 100,000Hz

Sensitivity

Phono, 2.5mV for 2.5V rated output (0.5mV IHF)
High Level, 250mV for 2.5V rated output (50mV IHF)
Power Amplifier Input, 2.5V for rated output

Signal To Noise Ratio (A Weighted)

90dB (84dB IHF) below 10mV input, Phono Input
100dB (90dB IHF) below rated output, High Level
110dB below rated output, Power Amplifier

Intermodulation Distortion

Maximum Intermodulation Distortion if instantaneous peak output per channel does not exceed twice the rated output, for any combination of frequencies from 20Hz to 20,000Hz, with all channels operating is:
0.005% for 2, 4 or 8 ohm loads

Input Impedance

Phono, 47k ohms, 65pF
High Level, 22k ohms

Maximum Input Signal

Phono, 90mV
High Level, 8V

Preamplifier Maximum Voltage Output

Phono, 8V at tape output
High Level, 8V at tape output
Main Out, 8V at preamp output

Voltage Gain

High Level to Tape: 0dB
High Level to Main: 20dB

Wide Band Damping Factor

Greater than 40

Power Requirements

- 100 Volts, ~ 50/60Hz at 4.8 amps
- 110 Volts, ~ 50/60Hz at 4.4 amps
- 120 Volts, ~ 50/60Hz at 4.2 amps
- 220 Volts, ~ 50/60Hz at 2.0 amps
- 230 Volts, ~ 50/60Hz at 2.0 amps
- 240 Volts, ~ 50/60Hz at 2.0 amps

Note: Refer to the rear panel of the MA6900 for the correct voltage.

Overall Dimensions

Front Panel: 17-1/2 inches (44.45cm) wide, 7-1/8 inches (18.10cm) high. Depth behind front mounting panel is 16-1/2 inches (41.91cm). Clearance required in front of the Front Panel is 1 inch (2.54cm) for knobs.

Weight

74.5 pounds (33.8 Kg) net, 92.5 pounds (41.7 Kg) in shipping carton

NOTES

1. The heavy lines on the schematic denote the primary signal path.
2. Unless otherwise noted, all voltages indicated on the schematics are measured under the following conditions:
 - a. AC input at 120 volts, 50/60Hz.
 - b. All voltages are +/-10% with respect to ground. A high impedance (10 megaohm) voltmeter must be used.
3. Unless otherwise specified:
 - a. Resistor values are in ohms.
 - b. Capacitor values are microfarads (uF).
 - c. Inductor values are in microhenries (uH).
4. On PC board drawings, Square pad indicates:
 - a. Polarized Capacitors - Positive
 - b. Diodes - Cathode
 - c. Others - Pin 1
5. **WARNING**
Parts marked with the symbol  have critical characteristics. Use only replacement parts recommended by the manufacturer.

Packing Instructions

In the event it is necessary to repack the equipment for shipment, the equipment must be packed exactly as shown below. It is very important that the four plastic feet are attached to the bottom of the equipment. Three #10 x 2-1/4 inch screws and washers must be used to fasten the unit securely to the bottom pad and wood skid. This will ensure the proper equipment location on the bottom pad. Failure to do this will result in shipping damage.

Use the original shipping carton and interior parts only if they are all in good serviceable condition. If a shipping carton or any of the interior part(s) are needed, please call or write Customer Service Department of McIntosh Laboratory. Please see the Part List for the correct part numbers.

Quantity	Part Number	Description
1	033888	Shipping carton only
2	033887	End cap (Foam pad)
1	033697	Inside carton only
1	033725	Top Pad
1	034008	Bottom pad
2	017218	Plastic foot (spacer)
1	033699	Wood skid
2	101204	#10 x 2-1/4 inch Wood screw
2	104033	#10 x 1-3/4 inch Flat washer
4	017218	Plastic foot
4	100159	#10-32 x 3/4 inch Machine screw
4	104083	#10 x 7/16 inch Flat washer
1	048572	Shipping Carton Complete

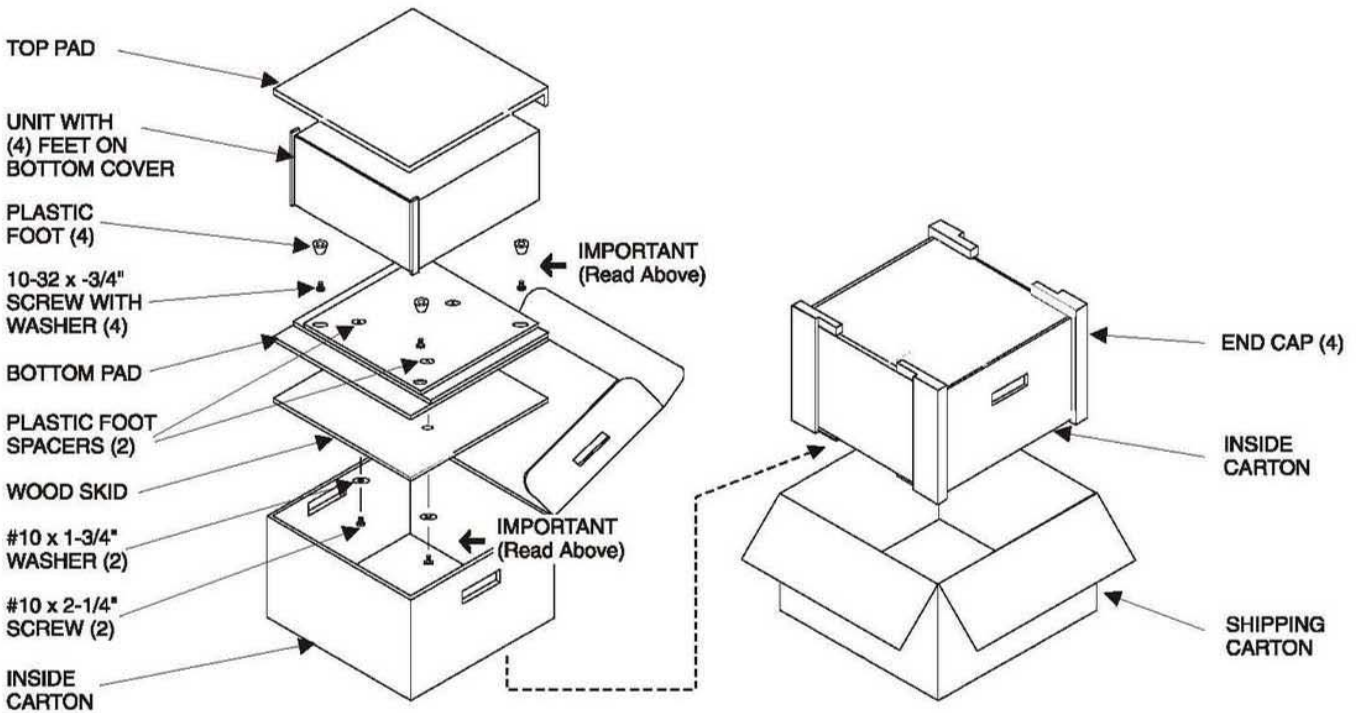



McIntosh Laboratory, Inc.
2 Chambers Street
Binghamton, NY 13903

The continuous improvement of its products is the policy of McIntosh Laboratory Incorporated who reserve the right to improve design without notice.

Printed in the U.S.A.

McIntosh Part No. 04099100